

ORDER NO. 23-116-05

ORDER APPROVING WILLIAMSON COUNTY LICENSE AGREEMENT

WHEREAS, Brushy Creek Municipal Utility District (the "District") is a municipal utility district created and operating under the authority of Chapters 49 and 54 of the Texas Water Code, as amended;

WHEREAS, Section 49.213(b) of the Texas Water Code authorizes a district to enter into contracts with any person or any public or private entity in the performance of any purpose or function permitted by a district;

WHEREAS, the Board of Directors of the District desires for the District to enter into the **Williamson County License Agreement**; and

NOW, THEREFORE, BE IT ORDERED BY THE BOARD OF DIRECTORS OF BRUSHY CREEK MUNICIPAL UTILITY DISTRICT, THAT:

SECTION 1. The facts and recitations in the preamble of this Order are hereby found and declared to be true and correct, and are incorporated by reference herein and expressly made a part hereof, as if copied verbatim.

SECTION 2. The Board of Directors hereby approves the contract attached hereto, and further authorizes the execution thereof by the President, Vice-President or General Manager of the District.

SECTION 3. Upon adoption, a copy of this Order shall be retained in the District's records and retained in accordance with the District's record retention policies.

RESOLVED this 16th day of November, 2023

BRUSHY CREEK MUNICIPAL UTILITY DISTRICT

By: 
President

ATTEST:

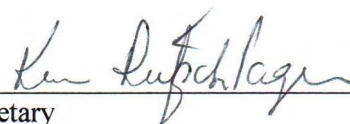
Secretary

WILLIAMSON COUNTY
LICENSE AGREEMENT

WILLIAMSON COUNTY, TEXAS a political subdivision of the State of Texas (the “County”), and the Brushy Creek Municipal Utility District, being a political subdivision of the State of Texas (the “Licensee”), enter into this License Agreement (the “Agreement”) upon the terms and conditions set forth below.

I. PURPOSE OF LICENSE AGREEMENT

Licensee has requested permission from County to install, operate, maintain and repair those certain improvements identified in **Exhibit “A”** attached hereto (collectively referred to herein as the “Licensee’s Improvements”) within the Williamson County right-of-way areas more particularly described in **Exhibit “B”** attached hereto (collectively, the “Licensed Property”). Subject to the terms and conditions of this Agreement, the County grants to Licensee permission to install, repair and maintain Licensee’s Improvements in the Licensed Property. The parties acknowledge that this Agreement does not apply to, or affect any interests, rights and obligations regarding water, wastewater, drainage facilities or other utilities located or to be located within the Licensed Property pursuant to any validly issued permits or executed easements related thereto.

The County makes this grant solely to the extent of its right, title and interest in the Licensed Property, without any express or implied warranties.

Licensee agrees that all construction, repair, operation and maintenance permitted by this Agreement shall be done in compliance with the terms and conditions of this Agreement and all applicable County, State and/or Federal police, traffic, building, health and safety ordinances, laws and regulations existing at the time said construction, repair, operation and maintenance is performed.

II. ANNUAL FEE

The County, its governing body, and its respective successors and assigns agree that no annual fee shall be assessed for the license and permission herein granted to Licensee. Licensee agrees that the County’s permission and grant of a license hereunder and Licensee’s ability to construct Licensee’s Improvements on the Licensed Property serve as consideration to support this Agreement.

III. COUNTY’S RIGHTS TO LICENSED PROPERTY

This Agreement is expressly subject and subordinate to the present and future rights of the County, its successors, assigns, lessees, grantees and licensees, to construct, install, establish, maintain, use, operate and renew any public utilities facilities, franchised public utilities, roadways or streets on, beneath or above the surface of the Licensed Property described in Article I above.

Nothing in this Agreement shall be construed to limit, in any way, the power of the County to widen, alter or improve the Licensed Property subject to this Agreement pursuant to official action by the governing body of the County or its successors. The County does, however, agree to give Licensee at least sixty (60) days written notice of such action and shall cooperate with

Licensee to effect the relocation and/or removal of Licensee's Improvements, at Licensee's sole cost, in the event of such widening, altering or improvement of the Licensed Property, further, to cooperate with Licensee wherever possible, to effect such widening, altering or improving of the Licensed Property so that Licensee's Improvements and operations on the Licensed Property will not be materially affected thereby.

Licensee hereby agrees and acknowledges that Licensee, at its expense, shall be responsible for removal of Licensee's Improvements from the Licensed Property within sixty (60) days of County's directive to remove specified Licensee's Improvements whenever such removal is deemed by County necessary for: (a) exercising the County's rights or duties with respect to the Licensed Property; (b) protecting persons or property; or (c) protecting the public health or safety with respect to the Licensed Property. In the event Licensee fails to remove the Licensee's Improvements to the County's satisfaction following County's directive to do so, then and in that event the County may cause the Improvements to be removed at the expense of Licensee.

Notwithstanding any provision in this Agreement to the contrary, the County retains the right to enter upon the Licensed Property, at any time without notice to Licensee, assuming no obligation to Licensee, and remove, repair or replace, without liability to County and at Licensee's expense, any of the Licensee's Improvements thereof whenever such removal is deemed by County necessary for: (a) exercising the County's rights or duties with respect to the Licensed Property; (b) protecting persons or property; or (c) protecting the public health or safety with respect to the Licensed Property.

IV. INSURANCE

Licensee shall, at its sole expense, provide a commercial general liability insurance or risk pool coverage, written by a company acceptable to the County and licensed to do business in Texas, with a combined single limit of not less than One Million and No/100 Dollars (\$1,000,000.00), which coverage may be provided in the form of a rider and/or endorsement to a previously existing insurance policy. Such insurance or risk pool coverage shall specifically name the County as an additional insured. This insurance coverage shall cover all perils arising from the activities of Licensee, its officers, directors, employees, agents or contractors, relative to this Agreement. Licensee shall be responsible for any deductibles stated in the policy. A true copy of each instrument effecting such coverage shall be delivered to the County on or before the Effective Date.

So long as Licensee is using the Licensed Property, Licensee shall not cause such insurance to be canceled nor permit such insurance to lapse. All insurance certificates shall include a clause to the effect that the policy shall not be canceled, reduced, restricted or otherwise limited until thirty (30) days after the County has received written notice as evidenced by a return receipt of registered or certified mail.

V. INDEMNIFICATION

INDEMNIFICATION - EMPLOYEE PERSONAL INJURY CLAIMS. TO THE FULLEST EXTENT PERMITTED BY LAW, THE LICENSEE SHALL INDEMNIFY, DEFEND, AND HOLD HARMLESS COUNTY, AND COUNTY'S EMPLOYEES, AGENTS, REPRESENTATIVES, PARTNERS, OFFICERS, AND DIRECTORS (COLLECTIVELY, THE "INDEMNITEES") AND SHALL ASSUME ENTIRE RESPONSIBILITY AND LIABILITY (OTHER THAN AS

A RESULT OF COUNTY'S GROSS NEGLIGENCE) FOR ANY CLAIM OR ACTION BASED ON OR ARISING OUT OF THE PERSONAL INJURY, OR DEATH, OF ANY EMPLOYEE OF THE LICENSEE, OR OF ANY SUBCONTRACTOR, OR OF ANY OTHER ENTITY FOR WHOSE ACTS THEY MAY BE LIABLE, WHICH OCCURRED OR WAS ALLEGED TO HAVE OCCURRED ON THE PROJECT SITE OR IN CONNECTION WITH THE PERFORMANCE OF THE WORK. LICENSEE HEREBY INDEMNIFIES THE INDEMNITEES EVEN TO THE EXTENT THAT SUCH PERSONAL INJURY WAS CAUSED OR ALLEGED TO HAVE BEEN CAUSED BY THE SOLE, COMPARATIVE OR CONCURRENT NEGLIGENCE OF THE STRICT LIABILITY OF ANY INDEMNIFIED PARTY. THIS INDEMNIFICATION SHALL NOT BE LIMITED TO DAMAGES, COMPENSATION, OR BENEFITS PAYABLE UNDER INSURANCE POLICIES, WORKERS COMPENSATION ACTS, DISABILITY BENEFITS ACTS, OR OTHER EMPLOYEES BENEFIT ACTS.

INDEMNIFICATION - OTHER THAN EMPLOYEE PERSONAL INJURY CLAIMS. TO THE FULLEST EXTENT PERMITTED BY LAW, LICENSEE SHALL INDEMNIFY, DEFEND (WITH COUNSEL OF COUNTY'S CHOOSING), AND HOLD HARMLESS INDEMNITEES FROM AND AGAINST CLAIMS, DAMAGES, LOSSES AND EXPENSES, INCLUDING BUT NOT LIMITED TO ATTORNEYS' FEES, ARISING OUT OF OR ALLEGED TO BE RESULTING FROM THE PERFORMANCE OF THIS AGREEMENT OR THE WORK DESCRIBED HEREIN, TO THE EXTENT CAUSED BY THE NEGLIGENCE, ACTS, ERRORS, OR OMISSIONS OF LICENSEE OR ITS SUBCONTRACTORS, ANYONE EMPLOYED BY THEM OR ANYONE FOR WHOSE ACTS THEY MAY BE LIABLE, REGARDLESS OF WHETHER OR NOT SUCH CLAIM, DAMAGE, LOSS OR EXPENSE IS CAUSED IN WHOLE OR IN PART BY A PARTY INDEMNIFIED HEREUNDER.

VI. CONDITIONS

A. Plan Review. Licensee's Improvements shall not be erected, placed, constructed or altered after being constructed on any of the Licensed Property until Licensee's plans and specifications for Licensee's Improvements have been approved, in writing, by County's Engineer or its authorized representatives. Licensee's required plans and specifications for all proposed improvements shall be submitted to County's Engineer and include necessary and applicable details such as site plan, landscape plans, irrigation plans, exterior elevations, drainage and grading plans and/or exterior materials. Approval of plans is at the sole discretion of the County's Engineer. The County Engineer will review all plans in the normal course of business and will make good faith efforts to issue remarks and approvals without unreasonable delay. Once the required plans and specifications are approved by the County Engineer, Licensee hereby acknowledges and agrees that the development and use of the Licensed Property shall thereafter be in strict compliance with the approved plans and specifications or approved amendments thereto.

B. Licensee's Responsibilities. Licensee will be responsible for any damage to and/or for the relocation of existing facilities on the Licensed Property. Further, Licensee shall reimburse the County for all costs of replacing or repairing any property of the County or of others which are damaged or destroyed as a result of activities authorized under this Agreement by, or on behalf of, Licensee.

C. Maintenance. Licensee shall maintain the Licensed Property and the Licensee's Improvements. If Licensee abandons or fails to maintain the Licensed Property, and the County receives no substantive response within fifteen (15) days following written notification to Licensee, then the County may, in addition to any other remedy set out herein, remove and/or replace all of Licensee's Improvements.

D. Removal or Modification. Licensee agrees that removal or modification of any improvements now existing or to be later replaced on the Licensed Property shall be at Licensee's sole expense. Said removal or modification shall be at Licensee's sole discretion, except where otherwise provided by this Agreement; provided, however, any modification to existing Licensee's Improvements must comply with the Plan Review requirements set out herein.

E. Default. In the event that Licensee fails to maintain the Licensed Property or otherwise comply with the terms or conditions as set forth herein, then the County shall give Licensee written notice thereof to the Licensee at the address set forth below. Licensee shall have sixty (60) days from the date of receipt of such notice to take action to remedy the failure complained of and, if Licensee does not remedy the same to County's complete satisfaction within the sixty (60) day period, the County may, in addition to other remedies available herein or by law to County, (1) perform the work, (2) contract for the completion of the work, or (3) terminate this Agreement. Licensee agrees to pay, within sixty (60) days of written demand by the County, all costs and expenses incurred by the County in completing the work or contracting for the work to be completed.

VII. COMMENCEMENT; TERMINATION BY ABANDONMENT

This Agreement shall be effective as of the date of the last party's execution below ("Effective Date"), and continue thereafter for so long as the Licensed Property shall be used for the purposes set forth herein or until this Agreement is terminated according to the terms hereof.

If Licensee abandons the use of all or any part of the Licensed Property for such purposes set forth in this Agreement, then this Agreement, as to such portion or portions abandoned, shall expire and terminate following fifteen (15) days written notice to the Licensee. If such abandonment has not been remedied by Licensee within such period, the County shall thereafter have the same complete title to the Licensed Property so abandoned as though this Agreement had never been made and shall have the right to enter on the Licensed Property and terminate the rights of Licensee, its successors and assigns hereunder. All installations of Licensee's Improvements that are not removed prior to County's termination of the license subject of this Agreement shall be deemed property of the County as of the effective date of County's termination.

VIII. TERMINATION

A. Termination by Licensee. This Agreement, or portion of the Licensed Property, may be terminated by Licensee by delivering written notice of termination to the County not later than thirty (30) days before the effective date of termination. If Licensee so terminates, then Licensee shall, within the 30-day notice period, remove from the Licensed Property, or such other portion thereof that is being terminated, installations of Licensee's Improvements. Any of Licensee's Improvements that are not removed within said period shall become the property of the County. Licensee hereby agrees and acknowledges that Licensee shall be liable to County for any damages caused to the Licensed Property by the removal of Licensee's Improvements.

B. Termination by County. In addition to any other termination rights set out herein, this Agreement may be revoked and terminated at any time by County if such revocation and

termination is reasonably required by the public interest (as hereinafter set forth), after providing not less than sixty (60) days written notice to the Licensee.

Subject to prior written notification to Licensee or its successors-in-interest, revocation and termination of this Agreement is reasonably required by the public interest if:

1. the County deems, in its sole discretion, that Licensee's Improvements, or a portion of them, interfere with the County's right-of-way;
2. use of the Licensed Property becomes necessary for a public purpose;
3. the Licensee's Improvements, or a portion of them, constitute a danger to the public which the County deems, in its sole discretion, not to be remediable by alteration or maintenance of such improvements;
4. despite sixty (60) days written notice to Licensee, the County deems, in its sole discretion, maintenance or alteration necessary to alleviate a danger to the public has not been made; or
5. Licensee fails to comply with the terms and conditions of this Agreement including, but not limited to, any insurance requirements specified herein.

IX. MISCELLANEOUS PROVISIONS

A. Venue and Governing Law. Each party to this Agreement hereby agrees and acknowledges that venue and jurisdiction of any suit, right, or cause of action arising out of or in connection with this Agreement shall lie exclusively in Williamson County, Texas. Furthermore, this Agreement shall be governed by and construed in accordance with the laws of the State of Texas, excluding, however, its choice of law rules.

B. Severability. If any provision of this Agreement shall be held invalid or unenforceable by any court of competent jurisdiction, such holding shall not invalidate or render unenforceable any other provision hereof, but rather this entire Agreement will be construed as if not containing the particular invalid or unenforceable provision or provisions, and the rights and obligation of the parties shall be construed and enforced in accordance therewith. The parties acknowledge that if any provision of this Agreement is determined to be invalid or unenforceable, it is the desire and intention of each that such provision be reformed and construed in such a manner that it will, to the maximum extent practicable, give effect to the intent of this Agreement and be deemed to be validated and enforceable.

C. Covenant Running With Land: Waiver of Default. This Agreement and all of the covenants herein shall run with the land; therefore, the conditions set forth herein shall inure to and bind each party's successors and assigns. Either party may waive any default of the other at any time, without affecting or impairing any right arising from any subsequent or other default.

D. Assignment. Licensee shall not assign, sublet or transfer its interest in this Agreement without the written consent of the County, which consent shall not be unreasonably withheld. In the event County agrees to Licensee's assignment of its interest in this Agreement and subject to the assignee's compliance with the insurance requirements set forth herein, if any, Licensee shall furnish to the County a copy of any such assignment or transfer of any of Licensee's rights in this

Agreement, including the name, date, address and contact person.

E. Notices. Excepts as specifically otherwise set forth herein, all notices, demands and requests for delivery of documents or information hereunder shall be in writing and shall be sent to the receiving party at the address identified below and be deemed to have been properly delivered and received (1) as of the time of delivery if personally delivered; (2) as of the time deposited in the mail system if sent by United States certified mail, return receipt requested, and postage prepaid; (3) as of the time of delivery to Federal Express (or comparable express delivery system) if sent by such method with all costs prepaid; or (4) as of the third (3rd) day following the date in which notice is sent by electronic mail (e-mail). All notices, demands and requests hereunder shall be addressed:

To Licensee At:

The address set forth below Licensee's signature block herein below.

To County At:

Williamson County Engineer
3151 S. E. Inner Loop
Georgetown, Texas 78626
E-mail: adam.boatright@wilco.org

with copy to: Williamson County Judge
710 Main Street, Ste. 101
Georgetown, Texas 78626

or to such other addresses which either party may so designate by sending notice as aforesaid.

F. Day. Unless otherwise set forth herein, all references herein to a "day" shall mean a calendar day and not a business day.

G. No Third-Party Beneficiaries. This Agreement is for the sole and exclusive benefit of the parties hereto, and nothing in this Agreement, express or implied, is intended to confer or shall be construed as conferring upon any other person any rights, remedies or any other type or types of benefits.

H. Compliance with Laws. Each party to this Agreement shall comply with all federal, state, and local laws, statutes, ordinances, rules and regulations, and the orders and decrees of any courts or administrative bodies or tribunals in any matter affecting the performance of this Agreement

I. Gender, Number and Headings. Words of any gender used in this Agreement shall be held and construed to include any other gender, and words in the singular number shall be held to include the plural, unless the context otherwise requires. The headings and section numbers are for convenience only and shall not be considered in interpreting or construing this Agreement.

J. Construction. Each party to this Agreement acknowledges that it and its counsel have reviewed this Agreement and that the normal rules of construction are not applicable and there will be no presumption that any ambiguities will be resolved against the drafting party in the interpretation of this Agreement.

K. No Waiver of Immunities. Nothing in this Agreement shall be deemed to waive, modify or amend any legal defense available at law or in equity to County, its past or present officers, employees, or agents or employees, nor to create any legal rights or claim on behalf of any third party. County does not waive, modify, or alter to any extent whatsoever the availability of the defense of governmental immunity under the laws of the State of Texas and of the United States.

L. Force Majeure. If the party obligated to perform is prevented from performance by reasons for which they are not responsible or circumstances beyond their control, including, but without limitation to, “acts of God”, abnormal weather conditions or other natural catastrophes, war, terrorist attacks, sabotage, computer viruses, riots, strikes, lockouts or other industrial disturbances, pandemics, epidemics, health emergencies, disease, plague, quarantine, travel restrictions, discovery of hazardous materials, differing or unforeseeable site conditions, acts of governmental agencies or authorities (whether or not such acts are made in response to other Force Majeure Events), or any other events or circumstances not within the reasonable control of the party affected, whether or not of a similar kind or nature to any of the foregoing (a “Force Majeure Event”). For the avoidance of doubt, Force Majeure Events include the Coronavirus (SARS Cov-2) and such related diseases (e.g. COVID- 19) outbreak., the other party shall grant such party relief from the performance of this Agreement. The burden of proof for the need of such relief shall rest upon the party obligated to perform. To obtain release based on force majeure, the party obligated to perform shall file a written request with the other party and take reasonable efforts undertaken to mitigate its effects.

M. Entire Agreement. This Agreement represents the entire and integrated Agreement between the parties hereto and supersedes all prior negotiations, representations, or agreements, either oral or written. This Agreement may be amended only by written instrument signed by each party to this Agreement. **NO OFFICIAL, EMPLOYEE, AGENT, OR REPRESENTATIVE OF THE COUNTY HAS ANY AUTHORITY, EITHER EXPRESS OR IMPLIED, TO AMEND THIS AGREEMENT, EXCEPT PURSUANT TO SUCH EXPRESS AUTHORITY AS MAY BE GRANTED BY THE COUNTY COMMISSIONERS COURT.**

TERMS AND CONDITIONS ACCEPTED, to be effective as of the date of the last party’s execution below (the “Effective Date”).

WILLIAMSON COUNTY, TEXAS
a political subdivision of the State of Texas

By: _____

Printed Name: _____

Representative Capacity: As Presiding Officer of the
Williamson County Commissioners Court

Date: _____, 20__

THE STATE OF TEXAS §
 §
COUNTY OF WILLIAMSON §

This instrument was acknowledged before me on this the _____ day of _____, 20__ by _____, as Presiding officer of the Williamson County Commissioners Court, on behalf of Williamson County, Texas.

NOTARY PUBLIC, State of Texas

LICENSEE:

BRUSHY CREEK MUNICIPAL UTILITY DISTRICT,
a conservation and reclamation district of the State of Texas

By: Michael Tucker

Printed Name: Michael B. Tucker

Title: President

Date: 11/16, 2023

Address for Notice:

16318 Great Oaks Drive
Round Rock, Texas 78681
Attn: General Manager
E-mail: S.Dalton@bcmud.org

THE STATE OF TEXAS §
 §
COUNTY OF WILLIAMSON §

This instrument was acknowledged before me on this the 16 day of November, 2023 by Michael Tucker, President of Board of Directors, a _____.

Chelsea Labitt
NOTARY PUBLIC, State of Texas



EXHIBIT "A"

LICENSEE'S IMPROVEMENTS

Licensed Improvements

1. O'Connor Median Sign: Monument sign located in median of O'Connor drive as depicted in Exhibit "B".
2. Brushy Creek Rd ROW Landscaping: Landscaping and Irrigation improvements in located in Brushy Creek Road right-of-way area as depicted in Exhibit "B".
3. Brushy Creek Rd trail lights: Three trail lights and meter box located in Brushy Creek Road right-of-way area as depicted in Exhibit "B", which were installed by the County through an interlocal agreement dated July 23, 2019, as part of project T4327 Great Oaks Drive Improvements at Brushy Creek.

EXHIBIT “B”

LICENSED PROPERTY

Exhibit "B"
 1. O'Connor Median Sign:



DATE: 7/17/2023 4:21:16 PM
 FILE: \\garver\inc_data\Projects\2023\23147000 - BCMUD - Parks\Drawings\01_SHEETS\BCM_DEMO-ENV_01.dgn

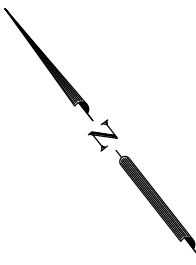

285 SE INNER LOOP
 SUITE 110
 GEORGETOWN, TX 78626
 (512) 485-0020

GARVER
 TBPE FIRM 5773



CONTRACT#
 DRAWN BY:
 DATE:

SCALE: 1" = 50'

BRUSHY CREEK MUNICIPAL UTILITY DISTRICT
 O'CONNOR DRIVE MEDIAN SIGN RELOCATION
 DIMENSIONING, DEMOLITION
 AND
 EROSION CONTROL

PRELIMINARY
 SUBJECT TO REVISION

This document is released for informational purposes under the authority of LAURA M. FRIELLO, P.E. 124810 on 7/17/2023. It is not to be used for regulatory approval, permit, bidding, or construction purposes.

SHEET NO.
 2
 OF
 18

Exhibit "B"
2. Brushy Creek Rd ROW Landscaping:

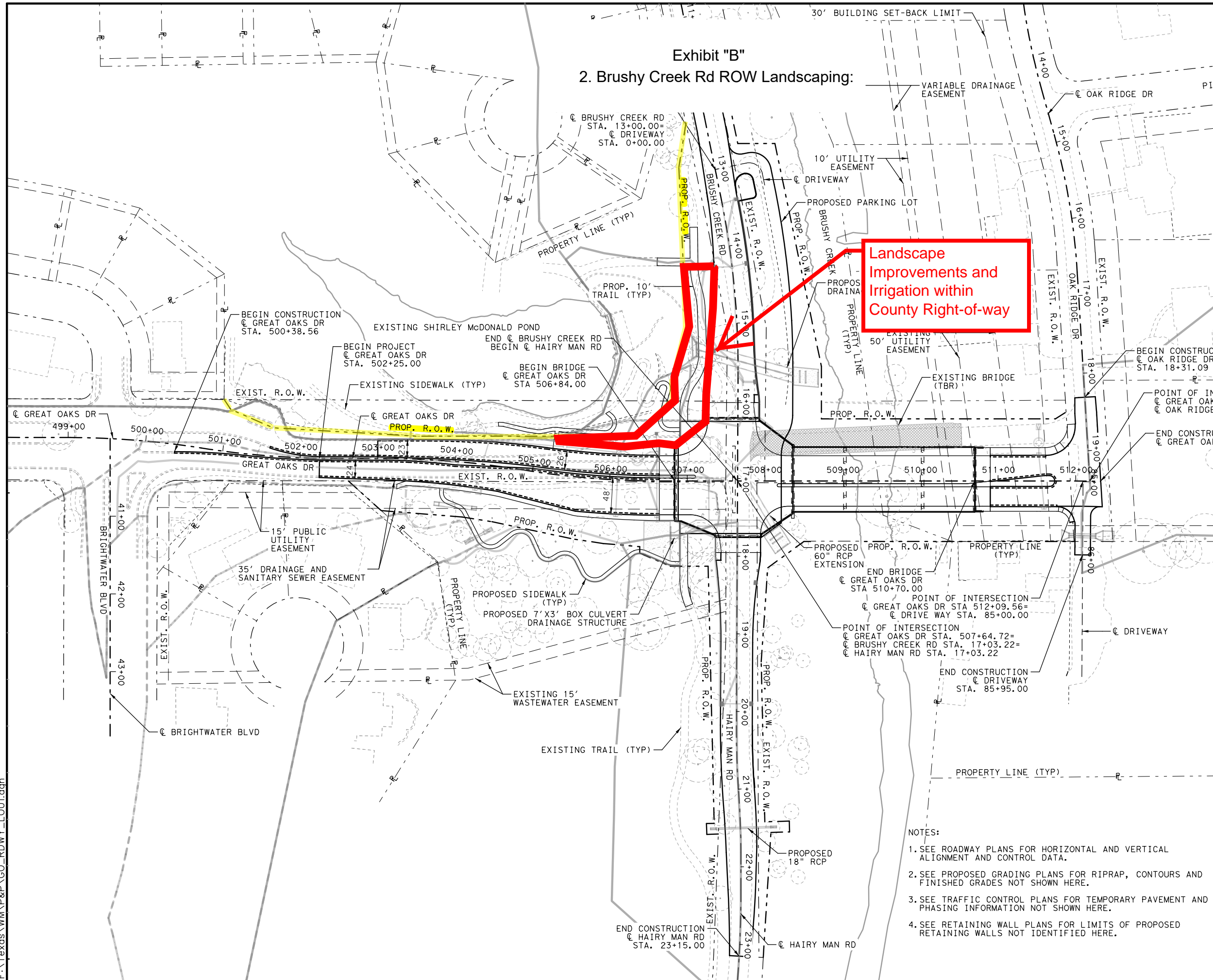
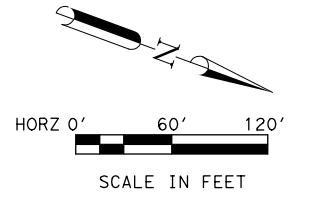

Landscape Improvements and Irrigation within County Right-of-way

12/17/2019

WILLIAMSON COUNTY
1848

JMT
TBPE REGISTRATION NO. F-16341

P.E. Structural Consultants, Inc.
www.PEStructural.com
TBPE Firm No. F-1475

GREAT OAKS DR AT BRUSHY CREEK RD
PROJECT LAYOUT

- NOTES:
1. SEE ROADWAY PLANS FOR HORIZONTAL AND VERTICAL ALIGNMENT AND CONTROL DATA.
 2. SEE PROPOSED GRADING PLANS FOR RIPRAP, CONTOURS AND FINISHED GRADES NOT SHOWN HERE.
 3. SEE TRAFFIC CONTROL PLANS FOR TEMPORARY PAVEMENT AND PHASING INFORMATION NOT SHOWN HERE.
 4. SEE RETAINING WALL PLANS FOR LIMITS OF PROPOSED RETAINING WALLS NOT IDENTIFIED.

12/18/2019		SHEET 1 OF 1	
DESIGN VLC	FED. RD. DIV. NO. 6	FEDERAL AID PROJECT NO.	HWY NO.
DRAWN JC	STATE TEXAS	DISTRICT AUS	COUNTY WILLIAMSON
DES CHECK RJM	AGI 6.5 W/C License Agreement		4
GR CHECK WES	Order 28-1116-05		OF 491

100% SUBMITTAL

ITEM	DESCRIPTION	1	2	3	4	5	6	7	8	9	10	11
	RUN LENGTH (FT)	180	5	40	101	15	15	21	24	35	17	17
GROUND	#10 BARE	1	1	1	1	1	1	1	1	1	1	1
ILLUMINATION	#10 XHHW	8	8	8	6	2	2	2	2	2	4	4
CONDUITS	2" PVC (SCH. 80)	1	1	1	1							
	2" PVC (SCH. 80) BORE											
	2" RIGID METAL					1	1	1	1	1	1	1

Exhibit "B"
3. Brushy Creek Rd trail lights (Page 1 of 2):

28	29	30	31	32	33	34	35	36	37	38	39	40	41	TOTAL (LF)
10	17	17	17	70	121	98	23	5	166	40	37	12	95	1644
1	1	1	1	1	1	1	1	1	1	1	1	1	1	5396
2	4	4	4	2	2	2	2	2	2	2	2	2	2	1131
					1	1	1	1	1	1	1	1	1	0
														513

LEGEND

- PROPOSED CONDUIT, MOUNTED TO STRUCTURE
- - - - PROPOSED CONDUIT, COMPLETE-IN-PLACE
- ==== PROPOSED BORE CONDUIT, COMPLETE-IN-PLACE
- PROPOSED GROUND BOX TYPE D
- PROPOSED GROUND BOX TYPE D W/ APRON
- PROPOSED FUSED DISCONNECT
- (XX) PROPOSED RUN NUMBER
- ☀ PROPOSED LIGHT FIXTURE
- ⊕ PROPOSED POLE MOUNTED LIGHT FIXTURE

FIXTURE	ILLUMINATION ASSEMBLY TYPE
UP-B-1-1	IN RD IL (U/P) (TY 2) (250 W EQ) LED
UP-B-1-2	IN RD IL (U/P) (TY 2) (250 W EQ) LED
UP-B-1-3	IN RD IL (U/P) (TY 2) (250 W EQ) LED
UP-B-1-4	IN RD IL (U/P) (TY 2) (250 W EQ) LED
UP-B-2-1	IN RD IL (U/P) (TY 2) (250 W EQ) LED
UP-B-2-2	IN RD IL (U/P) (TY 2) (250 W EQ) LED
UP-B-2-3	IN RD IL (U/P) (TY 2) (250 W EQ) LED
UP-B-2-4	IN RD IL (U/P) (TY 2) (250 W EQ) LED
UP-B-2-5	IN RD IL (U/P) (TY 2) (250 W EQ) LED
UP-B-2-6	IN RD IL (U/P) (TY 2) (250 W EQ) LED
UP-B-2-7	IN RD IL (U/P) (TY 2) (250 W EQ) LED
UP-B-2-8	IN RD IL (U/P) (TY 2) (250 W EQ) LED
UP-B-3-1	IN RD IL (U/P) (TY 2) (250 W EQ) LED
UP-B-3-2	IN RD IL (U/P) (TY 2) (250 W EQ) LED
UP-B-3-3	IN RD IL (U/P) (TY 2) (250 W EQ) LED
UP-B-3-4	IN RD IL (U/P) (TY 2) (250 W EQ) LED
UP-B-3-5	IN RD IL (U/P) (TY 2) (250 W EQ) LED
UP-B-3-6	IN RD IL (U/P) (TY 2) (250 W EQ) LED
IL-B-4-1	IN RD IL (TY SA) 20T-8 (250W EQ) LED
IL-B-4-2	IN RD IL (TY SA) 20T-8 (250W EQ) LED
IL-C-1-1	IN RD IL (U/P) (TY 2) (250 W EQ) LED
IL-C-1-2	IN RD IL (TY SA) 20T-8 (250W EQ) LED
IL-C-1-3	IN RD IL (TY SA) 20T-8 (250W EQ) LED

FIXTURE	STATION	OFFSET	SIDE
IL-B-4-1	15+10.49	25.44	LT
IL-B-4-2	14+12.41	25.38	LT
IL-C-1-1	506+53.21	48.41	LT
IL-C-1-2	15+89.37	43.57	RT
IL-C-1-3	14+19.79	27.85	RT
IL-D-1-1	503+76.20	0.00	-

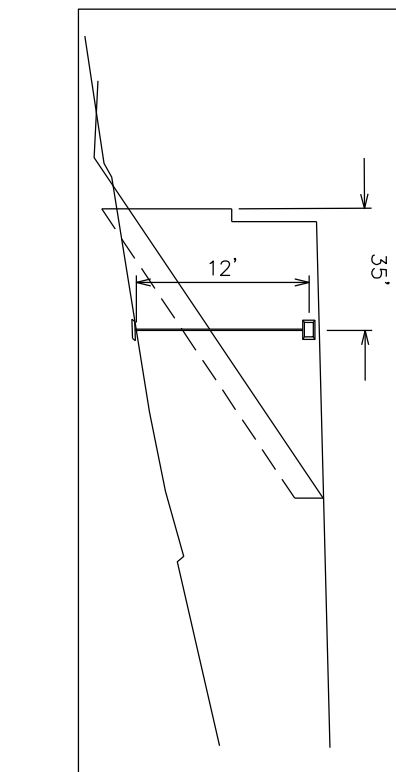

PARK SIDE LIGHTING ELEVATION (RET WALL RW-3L)
N.T.S.

NOTES:

- FOLLOW MANUFACTURERS MOUNTING INSTRUCTION FOR MOUNTING LIGHTING FIXTURES.
- CONTRACTOR IS RESPONSIBLE FOR LOCATING EXISTING UTILITIES AND EMPLOYING RESPONSIBLE CARE TO AVOID DAMAGING UTILITY FACILITIES.
- RUNS 3, 12, AND 22 ARE FROM GROUND BOX, UP BRIDGE COLUMN, TO FUSED DISCONNECT.
- RUN 36 IS FROM GROUND BOX, UP RAMP WALL, TO LIGHTING FIXTURE.
- LIGHTING FIXTURES MUST BE APPROVED BY WILLIAMSON COUNTY PRIOR TO INSTALLATION.

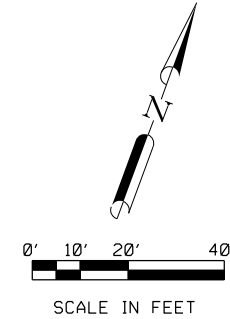
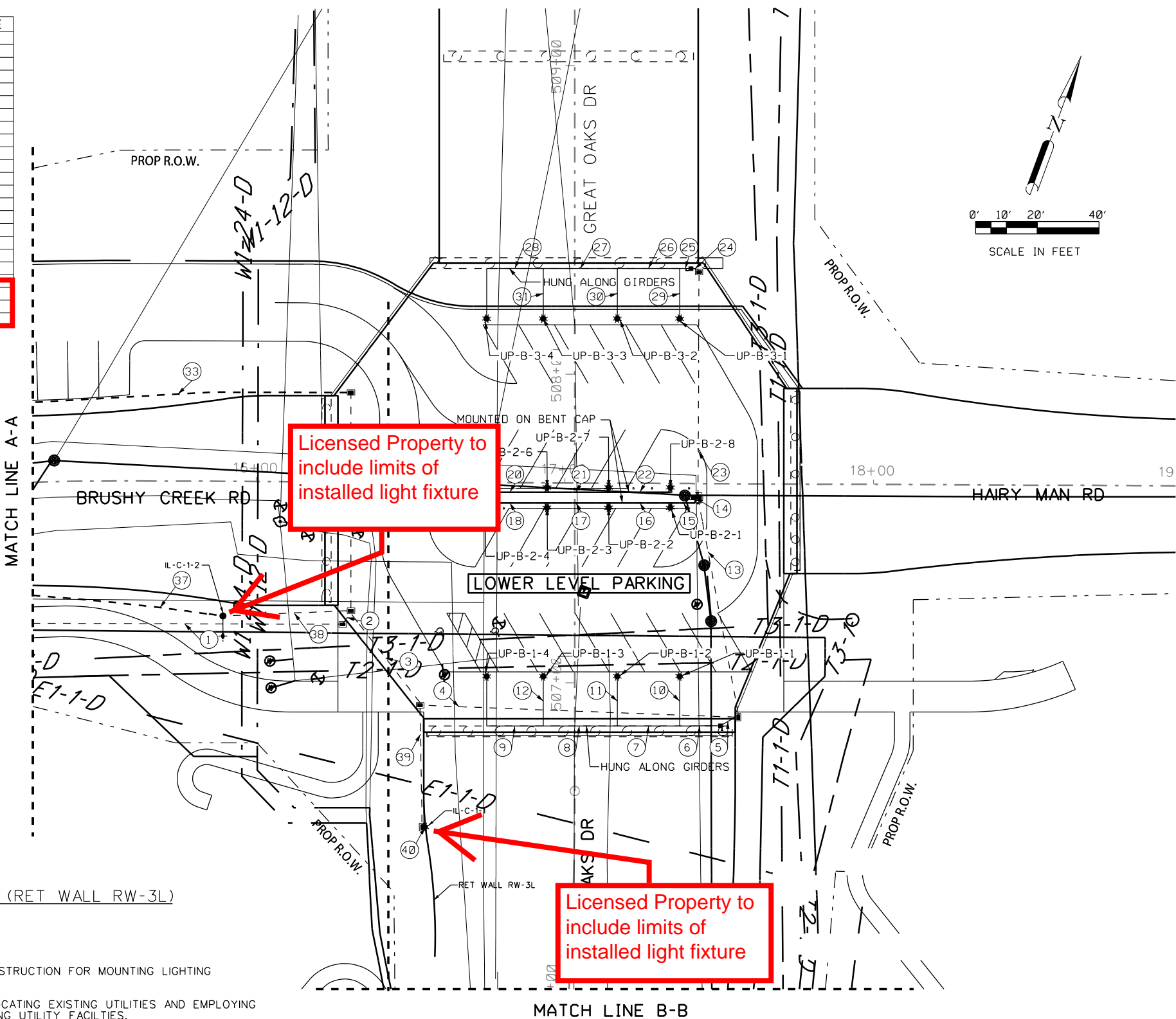

Karl F. Rothermel
10/16/2020

WILLIAMSON COUNTY
1848

Texas Registration No. 274

P.E. Structural Consultants, Inc.
www.PEStructural.com
TBPE Firm No. F-1475

GREAT OAKS DR AT BRUSHY CREEK RD

ILLUMINATION
PROPOSED PARKING
LEVEL LAYOUT

4/28/2021 SHEET 8 OF 11

DESIGN	FED. RD. DIV. NO.	FEDERAL AID PROJECT NO.	HWY NO.
JE	6		
DRAWN	STATE	DISTRICT	COUNTY
JE	TEXAS	AUS	WILLIAMSON
DES. CHECK	AGI 6.5 W/Co License Agreement		
KR	Order 23-1116-05		
DRN. CHECK	436 OF 491		
KR			

4/28/2021 4:11:24 PM \$FILEL\$

